

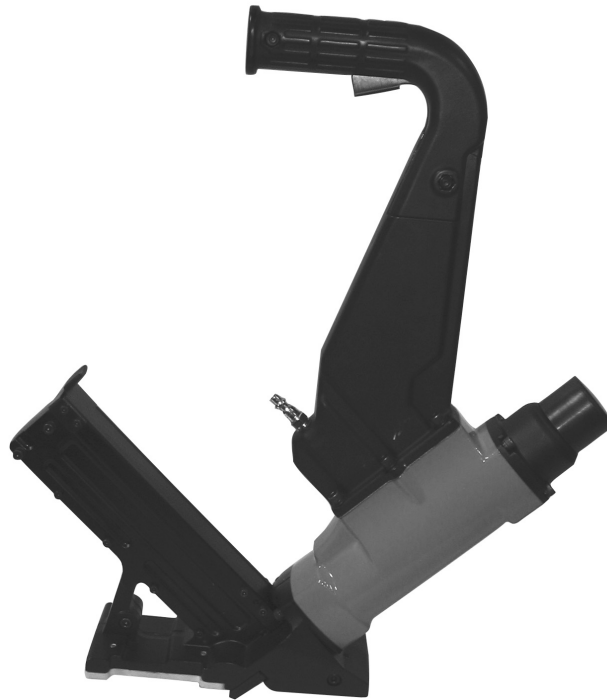

2 IN 1 FLOORING CLEAT/ STAPLE NAILER

Model 94446

ASSEMBLY AND OPERATING INSTRUCTIONS



3491 Mission Oaks Blvd., Camarillo, CA 93011
Visit our Web site at <http://www.harborfreight.com>

Copyright© 2006 by Harbor Freight Tools®. All rights reserved. No portion of this manual or any artwork contained herein may be reproduced in any shape or form without the express written consent of Harbor Freight Tools.

For technical questions and replacement parts, please call 1-800-444-3353

Specifications

Air Inlet	1/4"- 18 NPT
Working Air Pressure	60-125 PSI
Maximum Air Pressure	125 PSI *
Magazine Capacity	80
Air Consumption	4 CFM @ 125 PSI
Cleat Size Range	1-1/2" to 2" L-head Nails
Staple Size Range	1" to 2" Flooring Staples

*The air pressure setting must not exceed job site regulations/restrictions. The air pressure setting must not exceed 90 PSI when being used with work pieces that have a thickness of less than 1-3/4".

Save This Manual

You will need the manual for the safety warnings and precautions, assembly instructions, operating and maintenance procedures, parts list and diagram. Keep your invoice with this manual. Write the invoice number on the inside of the front cover. Keep the manual and invoice in a safe and dry place for future reference.

Safety Warnings and Precautions

WARNING: When using tool, basic safety precautions should always be followed to reduce the risk of personal injury and damage to equipment.

Read all instructions before using this tool!

1. **Keep work area clean.** Cluttered areas invite injuries.
2. **Observe work area conditions.** Do not use machines or power tools in damp or wet locations. Don't expose to rain. Keep work area well lighted. Do not use electrically powered tools in the presence of flammable gases or liquids.
3. **Keep children away.** Children must never be allowed in the work area. Do not let them handle machines, tools, extension cords, or air hoses.
4. **Store idle equipment.** When not in use, tools must be stored in a dry location to inhibit rust. Always lock up tools and keep out of reach of children.
5. **Use the right tool for the job.** Do not attempt to force a small tool or attachment to do the work of a larger industrial tool. There are certain applications for which this tool was designed. It will do the job better and more safely at the rate for which it was intended. Do not modify this tool and do not use this tool for a purpose for which it was not intended.
6. **Dress properly.** Do not wear loose clothing or jewelry as they can be caught in moving parts. Protective, electrically nonconductive clothes and nonskid footwear are recommended when working. Wear restrictive hair covering to contain long hair.
7. **Use eye and ear protection.** Always wear ANSI-approved impact safety goggles. Wear a full face shield if you are producing metal filings or wood chips. Wear an ANSI-approved dust mask or respirator when working around metal, wood, and chemical dusts and mists.

8. **Do not overreach.** Keep proper footing and balance at all times. Do not reach over or across running machines or air hoses.
9. **Maintain tools with care.** Keep tools clean for better and safer performance. Follow instructions for lubricating and changing accessories. Inspect tool cords and air hoses periodically and, if damaged, have them repaired by a qualified technician. The handles must be kept clean, dry, and free from oil and grease at all times.
10. **Disconnect air supply.** Disconnect air hose when not in use.
11. **Remove adjusting keys and wrenches.** Check that keys and adjusting wrenches are removed from the tool or machine work surface before plugging it in.
12. **Avoid unintentional starting.** Do not carry any tool while holding the trigger, whether it is plugged in or not.
13. **Stay alert.** Watch what you are doing, use common sense. Do not operate any tool when you are tired.
14. **Check for damaged parts.** Before using any tool, any part that appears damaged should be carefully checked to determine that it will operate properly and perform its intended function. Check for alignment and binding of moving parts; any broken parts or mounting fixtures; and any other condition that may affect proper operation. Any part that is damaged should be properly repaired or replaced by a qualified technician. Do not use the tool if any switch does not turn On and Off properly.
15. **Guard against electric shock.** Prevent body contact with grounded surfaces such as pipes, radiators, ranges, and refrigerator enclosures.
16. **Replacement parts and accessories.** When servicing, use only identical replacement parts. Use of any other parts will void the warranty. Only use accessories intended for use with this tool. Approved accessories are available from Harbor Freight Tools.
17. **Do not operate tool if under the influence of alcohol or drugs.** Read warning labels if taking prescription medicine to determine if your judgement or reflexes are impaired while taking drugs. If there is any doubt, do not operate the tool.
18. **Use proper size and type extension cord.** If an extension cord is required for the air compressor, it must be of the proper size and type to supply the correct current to the tool without heating up. Otherwise, the extension cord could melt and catch fire, or cause electrical damage to the tool. Check your compressor's manual for the appropriate size cord.
Note: Performance of the compressor (if powered by line voltage) may vary depending on variations in local line voltage. Extension cord usage may also affect tool performance.
19. **Maintenance.** For your safety, maintenance should be performed regularly by a qualified technician.
20. **Compressed air only.** Never use combustible gases as a power source.

Warning: The warnings, cautions, and instructions discussed in this instruction manual cannot cover all possible conditions and situations that may occur. It must be understood by the operator that common sense and caution are factors which cannot be built into this product, but must be supplied by the operator.

Unpacking

When unpacking, check to make sure the item is intact and undamaged. If any parts are missing or broken, please call Harbor Freight Tools at the number on the cover of this manual as soon as possible.

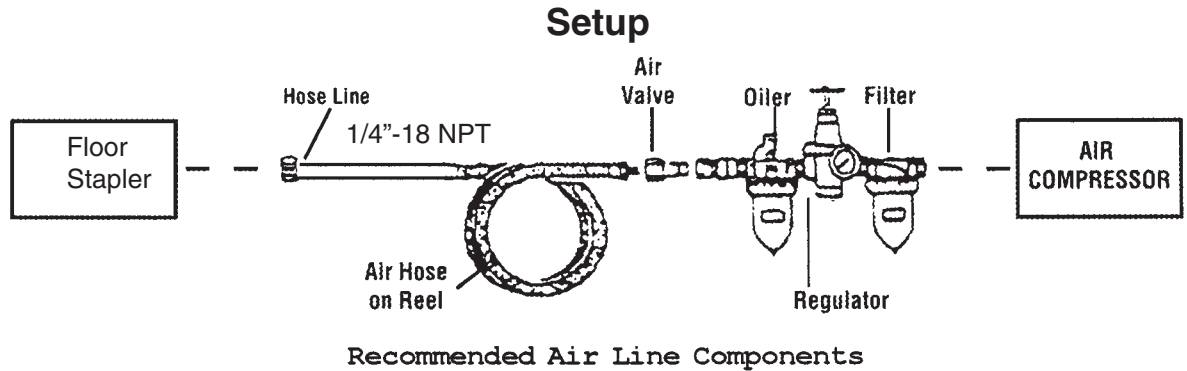

For best service you should incorporate an oiler, regulator, and inline filter, as shown in the diagram above. Hoses, couplers, oilers, regulators, and filters are all available at Harbor Freight Tools.

1. Wrap the Air Inlet (37) with pipe thread seal tape (not included) before threading it into the Arm (30). Connect the 3/8" ID Air Source Hose to the Air Inlet (37).

Note: If you are not using an automatic oiler system, before each use add a few drops of Pneumatic Tool Oil to the airline connection. Add a few drops more after each hour of continual use.

2. Set the air pressure on your compressor to between 60-125 PSI. Do not exceed the maximum air pressure of 125 PSI.
3. Check the air connection for leaks. Disconnect from the air source.

Loading the Tool

Warning! Disconnect the Stapler from the air compressor whenever loading or servicing. After disconnecting the Stapler from the air compressor, there could still be enough air pressure to fire the Stapler. After the air compressor hose is disconnected, always fire the Stapler into a piece of scrap to make sure all of the air is expended.

1. Grip the Sleeve (78) and pull out the Magazine Cover (72).

Caution: The Magazine Cover (72) may snap closed with force, sometimes without warning.

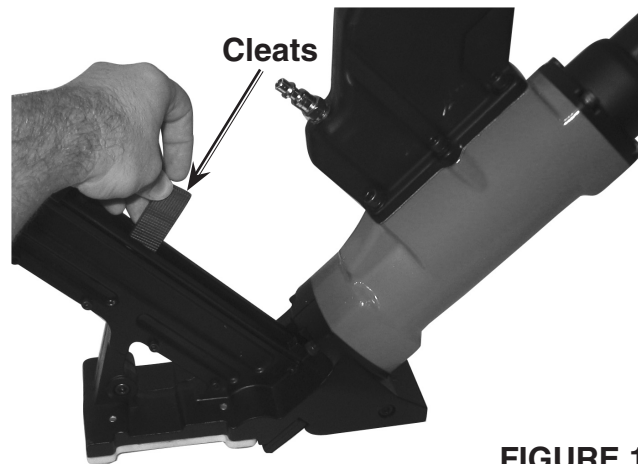

FIGURE 1

2. Install fasteners:

Cleats – Place the Cleats into the *larger* slot in the magazine so that the top of the cleat rests on the rail in the center of the magazine. See **Figure 1**, above.

Staples – Place the staples over the center rail of the magazine.

Note: Only use the fastener types and sizes listed on the Specifications Chart on page 2.

3. While holding the Sleeve (78) securely, slide the Magazine Cover (72) closed.

Operation

1. Connect the Floor Stapler to the air hose and turn on the air compressor.

Note: Before using on a floor, test the unit on a scrap piece of wood. Adjust the driving depth by providing more or less air pressure. Never exceed 125 PSI.

Warning! Keep your feet clear of the Stapler. Refer to **Figure 2**.

2. Hold the Handle (44) securely with one hand and grip the Hammer with the other hand.

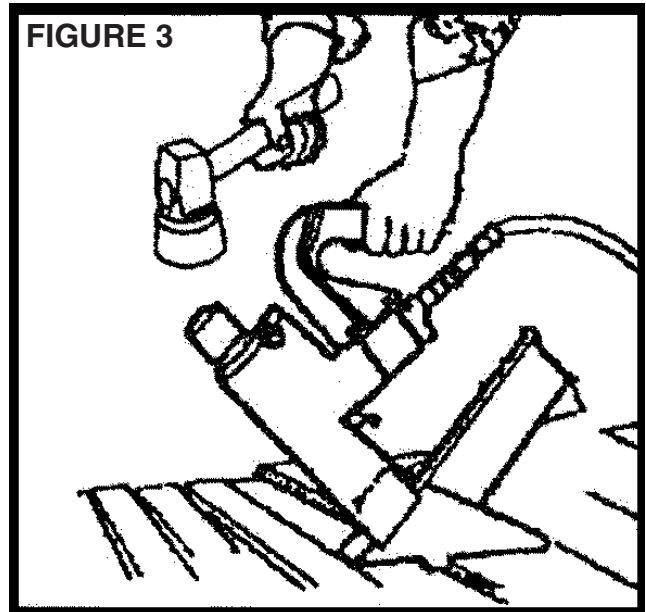
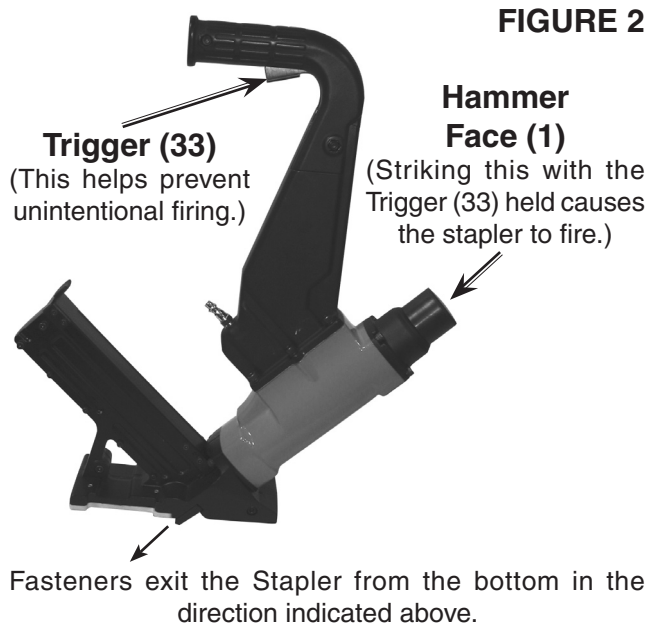

3. Make sure the Base Plate (52) is over the Fastener target position. Press down hard so that the Base Plate (52) is firmly contacting the floor. Then squeeze the Trigger (33) and strike the Hammer Face (1) with the Hammer to drive out a Fastener. Lift the tool off of the floor. See **Figure 3**.
4. Repeat the process until you are finished. Then, disconnect the Floor Stapler from the air source.

Warning! After disconnecting the Stapler from the air compressor, there could still be enough air pressure to fire the Stapler. After the air compressor hose is disconnected, always fire the Stapler into a piece of scrap to make sure all of the air is expended.

Anytime any maintenance or repairs are done (including clearing jams), FIRST:

1. Disconnect the Stapler from the air hose.
2. Empty Magazine (59, 69) completely.
3. Attempt to fire the Stapler into a piece of scrap wood to ensure that it is disconnected and is incapable of firing any Fasteners.
4. **Always leave Magazine Cover (72) closed during maintenance. The Magazine Cover is spring-loaded and may cause parts or a Fastener to fly out of the Stapler if it suddenly snaps closed.**

Clearing Jams

1. Disconnect tool from air hose, empty Magazine (59, 69) of Fasteners, release any built-up air pressure, and keep the magazine closed, as explained above.
2. While doing this step and the next, hold the Stapler pointed away from you and any other people or fragile objects. Remove all three Screws (49) and Washers (4) on the Driver Cover (48). See **Figure 4**.

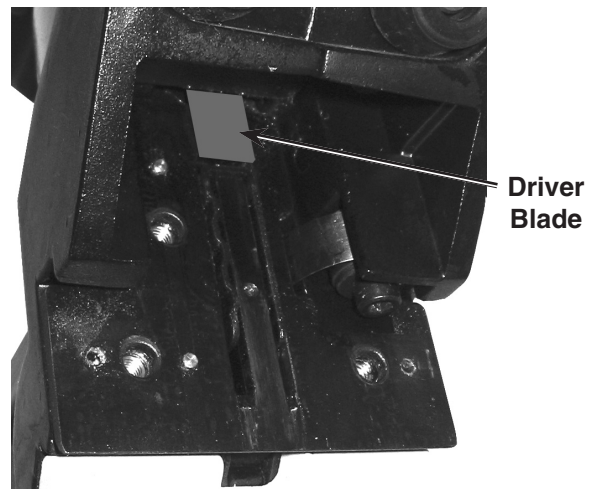

3. Carefully lift the Driver Cover (48) off and remove the jammed Fastener. Pliers may be necessary to remove a stuck Fastener.
4. Inspect the Driver on the end of the Piston Assembly (26) for bends or breakage. If it is damaged, do not use the tool until it is repaired by a qualified technician. See **Figure 5**.
5. Lightly oil the driver and replace the Driver Cover (48). Make sure that the Driver Cover (48) fits in place flush and that the Driver does not get pinched by it. Replace and securely tighten all of the Screws (49) and Washers (4).
6. Reload the Stapler and reconnect it to the air hose.
7. Press the tip of the Stapler against an appropriate piece of scrap wood.
8. Test fire the Stapler several times, checking for proper operation.
9. Disconnect the Stapler, remove the Fasteners, and store the Stapler in a location out of children's reach.

Anytime any maintenance or repairs are done, FIRST:

1. Disconnect the Stapler from the air hose.
2. Empty Magazine (59, 69) completely.
3. Attempt to fire the Stapler into a piece of scrap wood to ensure that it is disconnected and is incapable of firing any Fasteners.
4. **Always leave Magazine Cover (72) closed during maintenance. The Magazine Cover is spring-loaded and may cause parts or a Fastener to fly out of the Stapler if it suddenly snaps closed.**

Maintenance

1. Periodically lubricate all moving parts and pivots with a light oil.
2. Wipe down the Floor Stapler with a damp cloth. Do not use harsh detergents or solvents.
3. Check that the Base Plate (52) and the Hammer Face (1) is clear of any dirt or debris.

Troubleshooting

Note: Have the following problems repaired by a qualified service technician.

PROBLEM	CAUSE	SOLUTION
Air leaking in nose	1. Loose Nose Screws 2. Bumper is cracked/worn	1. Tighten and recheck 2. Replace Bumper
Lack of Power, slow to cycle.	1. Tool is too dry 2. Air Pressure is too low 3. Exhaust blocked	1. Lubricate 2. Check air supply equipment 3. Clean exhaust channel
Intermittent feeding or no fastener coming out	1. Damaged pusher spring 2. Wrong size Fastener 3. Dirty magazine or wearplate	1. Replace Spring 2. Use correct size 3. Clean magazine and nose
Jammed Fastener	1. Driver channel worn 2. Driver is broken/worn 3. Bent Fasteners	1. Replace wear plate 2. Replace driver 3. Use straight Fasteners

PLEASE READ THE FOLLOWING CAREFULLY

THE MANUFACTURER AND/OR DISTRIBUTOR HAS PROVIDED THE PARTS DIAGRAM IN THIS MANUAL AS A REFERENCE TOOL ONLY. NEITHER THE MANUFACTURER NOR DISTRIBUTOR MAKES ANY REPRESENTATION OR WARRANTY OF ANY KIND TO THE BUYER THAT HE OR SHE IS QUALIFIED TO MAKE ANY REPAIRS TO THE PRODUCT OR THAT HE OR SHE IS QUALIFIED TO REPLACE ANY PARTS OF THE PRODUCT. IN FACT, THE MANUFACTURER AND/OR DISTRIBUTOR EXPRESSLY STATES THAT ALL REPAIRS AND PARTS REPLACEMENTS SHOULD BE UNDERTAKEN BY CERTIFIED AND LICENSED TECHNICIANS AND NOT BY THE BUYER. THE BUYER ASSUMES ALL RISK AND LIABILITY ARISING OUT OF HIS OR HER REPAIRS TO THE ORIGINAL PRODUCT OR REPLACEMENT PARTS THERETO, OR ARISING OUT OF HIS OR HER INSTALLATION OF REPLACEMENT PARTS THERETO.

Parts List

Part	Description	Part	Description	Part	Description
1	Hammer Face	28	Bumper	55	Washer
2	O-ring 30.3 x 2.65	29	Seal	56	Coil Spring
3	Screw	30	Arm	57	Spring Bracket
4	Spring Washer	31	Handle A	58	Screw
5	Cylinder Cap	32	Locknut	59	Magazine A
6	Screw	33	Trigger	60	Washer
7	Spring Washer	34	Sleeve	61	Screw
8	Actuator A	35	Pin	62	Screw
9	Snap Ring	36	Pin	63	Plate
10	Half Block	37	Air Inlet	64	Limit Nut
11	Bushing	38	Spring	65	Support Plate A
12	O-ring 33.3 x 2.65	39	Trigger Valve Stem	66	Screw
13	Actuator B	40	O-ring 6.4 x 1.8	67	Spring Washer
14	O-ring 57.4 x 3.5	41	O-ring 11 x 1.4	68	Screw
15	Retaining Ring	42	Trigger Valve Guide	69	Magazine B
16	Poppet Cap	43	Screw	70	Bushing
17	O-ring 42 x 3.5	44	Handle B	71	Pin
18	Plunger	45	Screw	72	Magazine Cover
19	O-ring 21 x 2	46	Guide Body	73	Feeder
20	O-ring 14.3 x 2.5	47	Pin	74	Nut
21	Body	48	Driver Cover	75	Rail A
22	Cylinder	49	Screw	76	Orienting Plate
23	O-ring 17.5 x 2.6	50	Pin	77	Rail B
24	O-ring 38.5 x 4.5	51	Plate	78	Sleeve
25	Poppet	52	Base Plate	79	Screw
26	Piston Assembly	53	Screw	80	Support Plate B
27	O-ring 58.7 x 3.5	54	Pad	81	Magazine Handle

Assembly Diagram

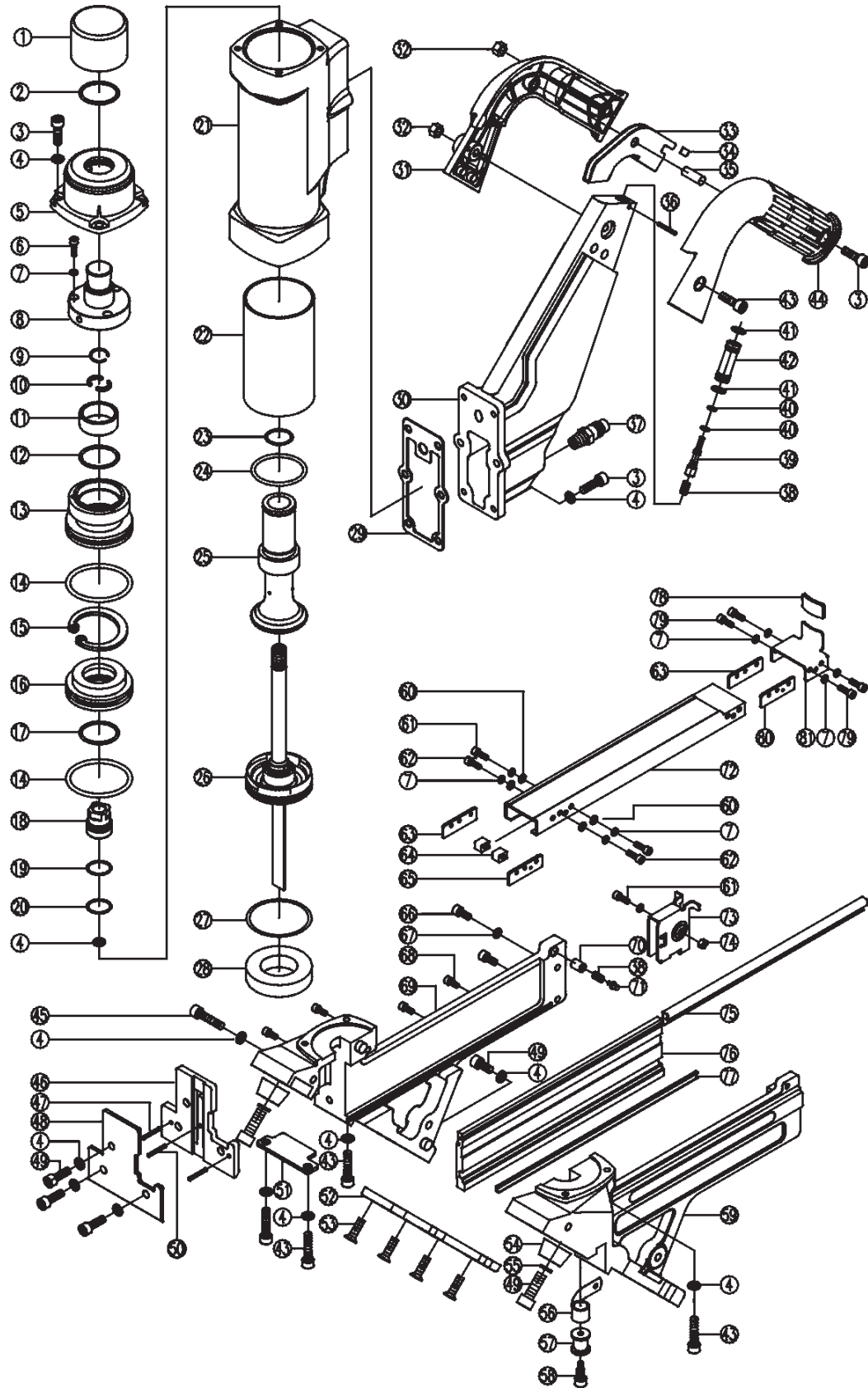



LIMITED 1 YEAR WARRANTY

Master Fastenal Tools Co. makes every effort to ensure that its products are of high quality and durability standards, and warrants to the original purchaser that it is protected by free from defects in materials and workmanship for the period of 1 year from the date of purchase. This warranty does not apply to damage due directly or indirectly, in whole or in part, to negligence, misuse, or alterations made to our facilities, or to lack of maintenance. We shall in no event be liable for death, injuries to persons or property, or for incidental, consequential, special or consequential damages arising from the use of our product. Some states do not allow the exclusion or limitation of incidental or consequential damages, so the above limitation of exclusion may not apply to you. THIS WARRANTY IS EXPRESSLY IN LIEU OF ALL OTHER WARRANTIES, EXPRESS OR IMPLIED, INCLUDING THE WARRANTIES OF MERCHANTABILITY AND FITNESS.

To take advantage of this warranty, the product or part must be returned to us with description, charges prepaid. Proof of purchase date and an explanation of the complaint must accompany the merchandise. If our inspection verifies the defect, we will either repair or replace the product at our election or you may elect to refund the purchase price. If we cannot readily and quickly provide you with a replacement, we will return repaired products at our expense, but if you determine there is no defect, or that the defect resulted from misuse and within the scope of our warranty, then you shall bear the cost of returning the product.

This warranty gives you specific legal rights and you may also have other rights which vary from state to state.

31-2000 Attention: Master Direct • P.O. Box 20000 • Minneapolis, MN 55420 • phone 444-3353